



LigoPTP 5-N R2

Quick Installation Guide

Revision 1.2
November 30, 2009

Copyright

© 2008 LigoWave

This user's guide and the software described in it are copyrighted with all rights reserved. No part of this publication may be reproduced, transmitted, transcribed, stored in a retrieval system, or translated into any language in any form by any means without the written permission of LigoWave.

Notice

LigoWave reserves the right to change specifications without prior notice.

While the information in this manual has been compiled with great care, it may not be deemed an assurance of product characteristics. LigoWave shall be liable only to the degree specified in the terms of sale and delivery.

The reproduction and distribution of the documentation and software supplied with this product and the use of its contents is subject to written authorization from LigoWave.

Trademarks

LigoWave logo is trademark of LigoWave LLC.

All other registered and unregistered trademarks in this document are the sole property of their respective owners.

FCC Warning

This equipment has been tested and found to comply with the limits for a Class B digital device, pursuant to Part 15 of the FCC Rules. These limits are designed to provide reasonable protection against harmful interference in a residential installation.

This equipment generates, uses, and can radiate radio frequency energy and, if not installed and used in accordance with the instructions, may cause harmful interference to radio communications. However, there is no guarantee that interference will not occur in a particular installation. If this equipment does cause harmful interference to radio or television reception, which can be determined by turning the equipment off and on, the user is encouraged to try to correct the interference by one of the following measures:

- Reorient or relocate the receiving antenna.
- Increase the separation between the equipment and receiver.
- Connect the equipment into an outlet on a circuit different from that to which the receiver is connected.
- Consult the dealer or an experienced radio/TV technician for help.

This device complies with Part 15 of the FCC Rules. Operation is subject to the following two conditions: (1) This device may not cause harmful interference, and (2) this device must accept any interference received, including interference that may cause undesired operation.

FCC Caution

To assure continued compliance, any changes or modifications not expressly approved by the party responsible for compliance could void the user's authority to operate this equipment.

FCC Radiation Exposure Statement

To comply with FCC RF exposure requirements in section 1.1307, a minimum separation distance of 3.9 feet is required between the antenna and all occupational persons, and a minimum separation distance of 8.7 feet is required between the antenna and all public persons.

Antenna Installation

WARNING: It is installer's responsibility to ensure that when using the authorized antennas in the United States (or where FCC rules apply), only those antennas certified with the product are used. The use of any antenna other than those certified with the product is expressly forbidden in accordance to FCC rules CFR47 part 15.204. The installer should configure the output power level of antennas, according to country regulations and per antenna type. Professional installation is required of equipment with connectors to ensure compliance with health and safety issues.

Antenna Compliance

The LigoPTP 5-N R2 radio module has been tested and certified with the following antennas:

- Dish (32.5dBi)
- Grid (27dBi)
- Panel (23dBi)

Any antenna of same make and lower gain than those listed above may be used in compliance with certification.

CE Mark Warning

This is a Class A product. In a domestic environment this product may cause radio interference in which case the user may be required to take adequate measures.

R&TTE Compliance Statement

This equipment complies with all the requirements of the Directive 1999/5/EC of the European Parliament and the Council of 9 March 1999 on Radio Equipment and Telecommunication Terminal Equipment and the Mutual Recognition of their Conformity (R&TTE).

The R&TTE Directive repeals and replaces in the directive 98/13/EEC (Telecommunications Terminal Equipment and Satellite Earth Station Equipment) As of April 8, 2000.

Safety

This equipment is designed with the utmost care for the safety of those who install and use it. However, special attention must be paid to the dangers of electric shock and static electricity when working with electrical equipment. All guidelines of this manual and of the computer manufacturer must therefore be allowed at all times to ensure the safe use of the equipment.

EU Countries Intended for Use

The ETSI version of this device is intended for home and office use in Austria, Belgium, Denmark, Finland, France (with Frequency channel restrictions), Germany, Greece, Ireland, Italy, Luxembourg, The Netherlands, Portugal, Spain, Sweden and United Kingdom.

The ETSI version of this device is also authorized for use in EFTA member states Iceland, Liechtenstein, Norway and Switzerland.

EU Countries Not Intended for Use

None.

Contents

Copyright	2
Notice	2
Trademarks	2
FCC Warning.....	3
FCC Caution	3
FCC Radiation Exposure Statement	3
Antenna Installation	3
Antenna Compliance	3
CE Mark Warning	4
R&TTE Compliance Statement	4
Safety.....	4
EU Countries Intended for Use	4
EU Countries Not Intended for Use.....	4
CONTENTS	5
ABOUT THIS GUIDE	6
Purpose	6
Definitions, Acronyms and Abbreviations.....	6
LigoWave Technical Support	6
Contact Us.....	6
INSTALLATION	7
Package Contents.....	7
Hardware Introduction.....	7
General Overview.....	7
Connectors.....	8
Mounting the LigoPTP 5-N R2.....	9
ACCESS THE LIGOPTP 5-N R2	10
Connection via WEB browser.....	10
Resetting to Factory Defaults	11

About This Guide

Purpose

The purpose of this guide is to provide a quick and easy explanation of getting started with the LigoPTP 5-N R2. This is only a starter guide and full documentation may be found at our online wiki: <http://www.ligowave.com/wiki>

Definitions, Acronyms and Abbreviations

The following typographic conventions and symbols are used throughout this document:



Additional information that may be helpful but which is not required.



Important information that should be observed.

LigoWave Technical Support

If you encounter problems when installing or using this product, please consult the LigoWave website at www.ligowave.com for:

- Direct contact to the LigoWave support centers.
- Frequently Asked Questions (FAQ).
- Download area for the latest software, user documentation and product updates.

Contact Us

EU office:

UAB WILIBOX
Veiveriu 150 - IIIa.
Kaunas, LT-46391
Lithuania

Phone +370 37 759007
Fax +370 37 759006
(UTC +2)

US office:

LigoWave
138 Mountain Brook Dr
Canton, GA 30115
United States of America

Phone +1 877 544 6928 (1 877 LIGOWAVE)
+1 678 490 0108
(UTC -5)

Installation

This chapter provides installation instructions for the hardware and software components of the LigoPTP 5-N R2. It also includes the procedures for the following tasks:

- Hardware Introduction (LEDs, Connectors)
- Mounting LigoPTP 5-N R2
- Connecting the device

Package Contents

The LigoPTP 5-N R2 comes with the following:

Component Name	Quantity
Articulating Mounting Bracket Hardware	1
CAT5 Connector Cap	1
Integrated PoE Power Supply & Injector	1



If any of these items are missing or damaged, please contact your reseller or LigoWave sales representative.

Hardware Introduction

General Overview

The LigoPTP 5-N R2 is housed in an aluminum enclosure and features an N-female type connector for use with external antennas.

The bottom panel of the LigoPTP 5-N R2 contains:

- **A window** to allow viewing of a series of indicator lights (**LEDs**) that help describe the state of various networking and connection operations.
- **Data/Power connection** in the form of passive PoE through standard Ethernet cable
- **N-Female** type antenna connector

The label of the LigoPTP 5-N R2 contains:

- **Model** name. The official model name is **LigoPTP 5-N R2**.
- **FCC ID**. The FCC ID is V2V-WMR560

Connectors

The LigoPTP 5-N R2 has several connectors on the bottom and side panels.

Descriptions of the connectors are given in the following table:

Connector	Description
PoE	For insertion of power and data through Ethernet cable using passive PoE
Antenna	External antenna connector (type N-Female)

Mounting the LigoPTP 5-N R2

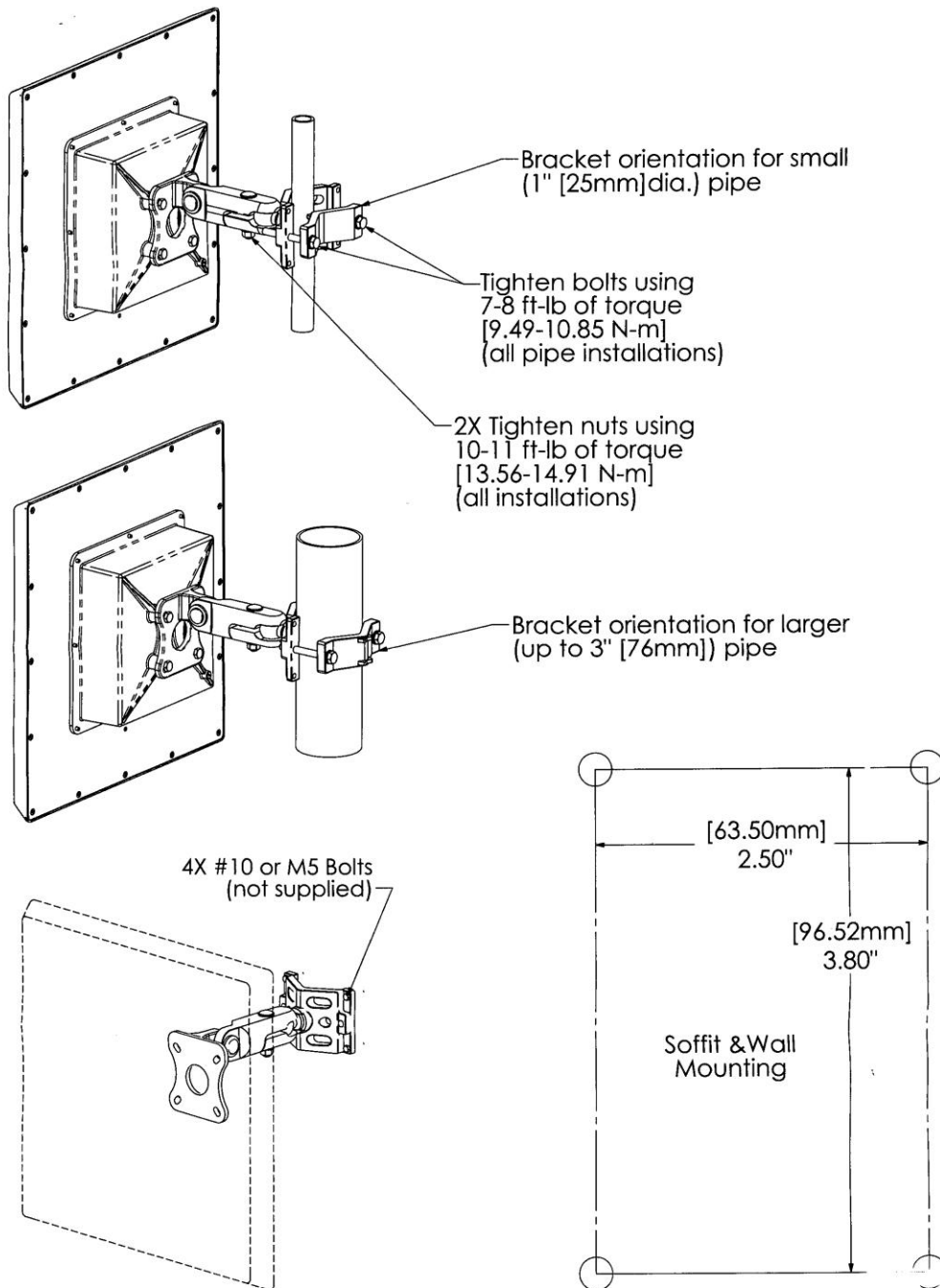

Access the LigoPTP 5-N R2

The first connection to the LigoPTP 5-N R2 can be made using a standard Ethernet cable connected directly to your PC. See next sections for the instructions on how to access the LigoPTP 5-N R2 management interfaces.

Connection via WEB browser

The default IP address of the LigoPTP 5-N R2 is 192.168.2.66 with a subnet mask of 255.255.255.0.

- Step 1** Configure your PC with a static IP address on the 192.168.2.0 subnet with mask 255.255.255.0. Connect the LigoPTP 5-N R2 Ethernet interface in to the same physical network as your PC. Open the Web browser and type the default IP address of the LigoPTP 5-N R2: <https://192.168.2.66/>



- Step 2** Enter the LigoPTP 5-N R2 administrator login details to access the Web management:



The default administrator login settings for all LigoPTP 5-N R2 are:
User Name: **admin**
Password: **admin01**

- Step 3** After successful administrator log on you will see the main page of the LigoPTP 5-N R2 Web management interface. The LigoPTP 5-N R2 now is ready for configuration. For further instructions on Web management refer to the respective document at the LigoWave wiki at <http://www.ligowave.com/wiki>

:

Resetting to Factory Defaults

LigoWave products have the capability of being reset to defaults by pinging the device with a certain packet size when the radio is booting.

During the startup of the device, when the drivers of the ethernet interfaces are loaded, the discovery daemon is started. The daemon suspends startup process for 3 seconds and waits for ICMP *"echo request"* packet of length 369 bytes. If the packet received, the discoveryd resets the device to default configuration.

Steps to reset to default settings:

Step 1. Power off the device.

Step 2. Obtain the device MAC address.

Step 3. Connect a PC to the same physical subnet as the device.

Step 4. Execute 'arp -s' command to assign the IP address (IP address should be from the same subnet as PC) to the device MAC address:

```
arp -s <IP address to assign> <device MAC address>
```

Step 5. Start pinging the device:

For linux users:

```
ping <IP address> -s 369
```

For Windows users:

```
ping <IP address> -l 369 -t -w 0.2
```

Step 6. Power up device and wait about 30sec or more (depends from device hardware).